

## CSI 2600 Machinery Health Expert



The CSI 2600 Machinery Health Expert combines the portability of the CSI 2130 Machinery Health Analyzer with the online capabilities of the CSI 6500 Machinery Health Monitor.

- *Portable, 24-channel machinery health monitor and analyzer helps troubleshoot your entire machine or group of machines*
- *Includes transient analysis for turbo machinery startup, coast down, and production state monitoring*
- *Monitor and record all channels continuously and simultaneously for hours, days, or weeks – unattended*
- *AMS Suite integration saves time and facilitates multi-technology integration*
- *PeakVue™ technology can be added for early identification of bearing wear in paper machines, rolling mills, complex gearboxes and rolling element bearing machines*



*The CSI 2600 is designed to sit upright, fit in tight spaces, or lay on its side to support your laptop. The hinged back door enables direct access to termination panels, providing numerous sensor-mounting options.*

## Introduction

Portable vibration analyzers are the cornerstone of a successful predictive maintenance program. However, some anomalies, like root cause investigations and machine train evaluations, can surpass the capabilities of even the most sophisticated 2-channel portable data collector. For example, turbo machinery start-ups, coast downs and production state monitoring require multi-channel, simultaneous recording, vibration monitoring, and real-time feedback to capture rapidly changing events across an entire machine train.

For balance of plant critical machines, a mobile, multi-channel monitoring solution with rolling element and gearbox monitoring technology is necessary for root cause analysis and to determine if the machine will survive to the next outage.

## One Tool to Fit Many Needs

Emerson's CSI 2600 Machinery Health Expert satisfies the need between two-channel portable analyzers and permanently-installed online vibration monitoring by borrowing the best from both solutions. Before a planned outage, connect all 24 channels of the CSI 2600 to simultaneously record continuous time waveforms. With AMS Suite: Machinery Health Manager, view waveforms, spectral data, and live orbits. Replay events using a customized view for further analysis, or replay as a presentation to the maintenance staff. Configure the CSI 2600 for waveform processing using PeakVue technology, order tracking, time synchronous averaging, or predefined parameters for advanced analysis.

The CSI 2600 can be configured and applied in a variety of applications — diagnosing a suspected load, speed, or batch-dependent problem, bringing a new machine online, or verifying critical speed prior to machine acceptance from the vendor.

## Innovative, Powerful

The CSI 2600 is a data collector, data viewer, data recorder and data manager in a single instrument. This unique tool can record continuous-time waveforms over 100 hours in length and allows you to view live plots with updates as fast as 5 times per second. The CSI 2600 also offers:

- 8-256 hours of continuous, simultaneous data recording
- Live plot displays
- Replay mode (play, rewind, fast forward, stop, auto-repeat)
- Complete plot control during Replay mode
- Support for external hard drive arrays to extend recording and storage options

The CSI 2600 Machinery Health Expert interfaces directly with a laptop computer for immediate access to all data using AMS Machinery Manager. The laptop can be disconnected for unattended recording.

## Getting Started is Simple and Fast

Connect the BNC cables from the protection rack or your accelerometers to the termination panel of the CSI 2600 and turn the power switch on. With a library of database templates to choose from, setup is simple and fast. Choose a template and 24 channels of vibration and 4 channels of speed/phase will begin recording. Connect the Ethernet cable and use your laptop to view live rotor diagnostic displays. Select Live View and your saved preferences for viewing orbits, shaft centerlines, waveforms, spectrums, and trends automatically display.

## Continuous Data Recording, No Snapshots

The unique architecture of the monitor allows for these very powerful capabilities:

- Data recording is both continuous and simultaneous on all channels versus snapshots of data
- Monitoring and recording function remain uninterrupted, even while you perform data manipulation (such as live data viewing, analysis or even manual data extraction) via AMS Machinery Manager

## Instant Replay

The Replay Mode is one of the most powerful analyzing tools introduced in AMS Machinery Manager v5.0. During Replay Mode, saved data from transient events can be used to simulate an event in real-time. Fast forward, rewind, or use slow motion and auto-repeat to view the event. Spread plots across dual monitors and select new filters as you replay the orbit plots. By controlling every view and all of the data generated by the event, you can analyze any machine event at your own convenience.

## Rolling Element Bearing Monitoring

The CSI 2600 includes an option to add Emerson's PeakVue technology — a unique expert approach to monitoring the distinct characteristics of bearing and gearbox problems. The PeakVue technology utilizes a 6400-line resolution, 40kHz Fmax, and over 60,000 rolling element bearing fault frequency data files to deliver the earliest indication of developing bearing faults. In addition, the CSI 2600 includes order tracking, definable data collection strategies, configurable analysis techniques, and unattended automatic event-based monitoring for customizing the data you collect during an event.

## Enclosure Specs for CSI 2600

### Enclosure Dimensions

- **CSI 2600:** 8 ¼" W x 16" D x 20 ¼" H  
Weight 29.8 lbs
- **Case:** 19.5W x 24.5"D x 13.75"H  
Weight 23 lbs
- Temperature 0°C - 48°C
- 0 – 95% Relative Humidity

### General

- 120 - 240 VAC autosensing input
- 80 watts power consumption
- X2 10/100BaseT Ethernet
- Includes fan
- CE approved

### Recommended Laptop Specs

- Emerson part number, A4500H5
- Dell E6410, Intel Core 2 Duo P8700, 2.53GHz
- 4.0GB memory
- 256MB NVIDIA Quadro NVS video driver
- 14.1 inch wide screen display, WXGA 1280 x 800 LED
- 160 GB hard drive, 5400 rpm
- Windows 7 professional
- 8X DVD +- RW
- 4.26 lbs
- Dell wireless LAN



*The enclosure surrounding the CSI 2600 was designed for travel. It is rugged and durable, appropriate for travel to/from monitoring sites.*

## CSI 2600 Machinery Health Expert Includes:

- Transient analysis for turbo machinery
- Transient processor: 51,200 lines of resolution, 2 kHz Fmax simultaneous
- Integration with AMS Machinery Manager
- Turbine replay\*
- 12 or 24 channels of simultaneous, continuous data acquisition
- Live plots, updating 5 times per second
- 100+ hours of data recording
- Runout subtraction
- Acceptance regions\*
- Drag and drop baseline on live plots
- 3D rotate cascade plots\*
- Integration with CSI 2130 Machinery Health Analyzer
- 2 or 4 speed/phase sensors channels
- 24+ user-definable analysis parameters per channel
- Unattended or automatic event-based, adaptive monitoring
- Event monitoring based on speed, overall vibration level, using DC input level or relay input, with Boolean combinations
- Automatic export to ME'Scope\*
- Customized filtered orbits
- Multi-colored plots for easy analysis\*

\*Denotes AMS Machinery Manager v5.0 or higher

## Options

- PeakVue processor (6400 lines, 40 kHz Fmax) scanning
- ME'Scope integration: Export data to a 3D graphical motion picture of the machine
- PeakVue software to export rolling element bearing and gearbox analysis
- Sensors: Complete selection of accelerometer, dual temperature/accelerometers, velometers, tachometers and displacement probes
- Mounting pads, magnetic bases
- Turbo Machinery Diagnostic training and PE credit hours provided by recognized leaders in this field
- Remote configuration or analysis support via dial-up or onsite service
- BNC cables, connectors, extension cables
- Spare parts
- AMS Machinery Manager
- External hard drive\*

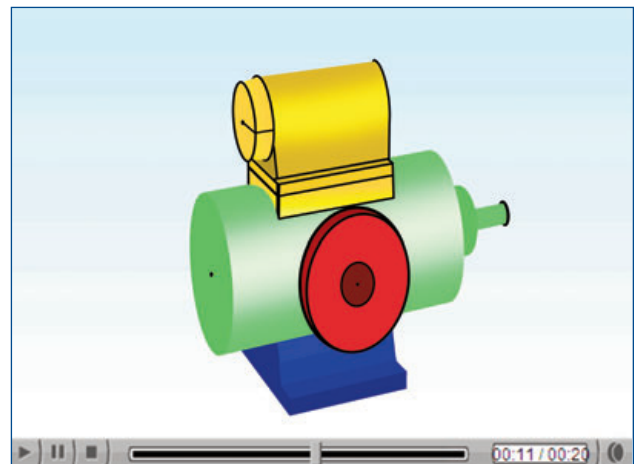

*ME'Scope offers a 3-dimensional "live" view of machinery, often identifying problems not seen in static images.*

**Order Information**

**CSI 2600 Machinery Health Expert**

|  |         |
|--|---------|
| Transient DVR*, Machinery Health Processor, 24 ch, 4 tach, 4 relay | A2600T8 |
| Transient DVR*, Machinery Health Processor, 12 ch, 2 tach, 2 relay | A2600T7 |
| Machinery Health Processor, 24 ch, 4 tach, 4 relay                 | A2600M8 |
| Machinery Health Processor, 12 ch, 2 tach, 2 relay                 | A2600M7 |

\*DVR - digital vibration recorder

**Software Options for the New User**

|   |         |
|---|---------|
| AMS Machinery Manager VibView Online only   | A474505 |
| Transient Analysis and Plotting Tools, per concurrent user seat (software support agreement must be up-to-date) | A474507 |
| Unlimited Online Watch and Online Config license (included with A474505)  | A474500 |
| PeakVue Firmware  | A476514 |

**Software Options for Existing AMS Machinery Manager Users**

|   |           |
|---|-----------|
| AMS Machinery Manager VibView Online only   | A474505-A |
| Transient Analysis and Plotting Tools, per concurrent user seat (software support agreement must be up-to-date) | A474507   |
| Unlimited Online Watch and Online Config license (included with A474505)  | A474500   |
| PeakVue Firmware  | A476514   |

**Services**

|   |                |
|---|----------------|
| 2-day onsite startup services, including setup and informal onsite training | AO-SERV-ONLINE |
| Hardware support, per year per unit   | SUPPORT-26-1   |

**Accessories included in the purchase of the CSI 2600:**

|  |           |
|--|-----------|
| Accessory pack includes the following:         | A2600ACC  |
| Cable ASM 3 cond with plug & rect 125v         | MHM-65010 |
| Fan filter, 120mm, 45ppi foam                  | MHM-94987 |
| Category 5E patch cord, 7', blue               | MHM-64986 |
| Cable ASM RS-232 data cable, DB9M-F, 6'        | MHM-65137 |
| Conn Plug 3P straight, screw mount (PN1834916) | MHM-60251 |
| Pellican case, 19.5" x 24.5" x 13.75"          | D25334    |

**Emerson Process Management**

**Asset Optimization Division**

835 Innovation Drive  
Knoxville, TN 37932  
T (865) 675-2400  
F (865) 218-1401

©2011, Emerson Process Management.

The contents of this publication are presented for informational purposes only, and while every effort has been made to ensure their accuracy, they are not to be construed as warranties or guarantees, express or implied, regarding the products or services described herein or their use or applicability. All sales are governed by our terms and conditions, which are available on request. We reserve the right to modify or improve the designs or specifications of our products at any time without notice.

All rights reserved. AMS, PeakVue, and Machinery Health are marks of one of the Emerson Process Management group of companies. The Emerson logo is a trademark and service mark of Emerson Electric Co. All other marks are the property of their respective owners.